

# LOGSET 8H GTE

## A STEADY AND STRONG HARVESTER FOR VARYING TERRAIN

### COMPONENTS IN BALANCE

The Logset 8H GTE harvester performs with ease in forests with small to large size trees and varying terrain. The size of the engine, the hydraulics and the mechanical parts of the machine are perfectly dimensioned – making the Logset design optimal compared to other harvesters in its size class. The Logset 8H GTE has a Mesera 240H crane (or a Mesera 220H as an option), with an outreach up to 11.1 meters.

The harvester can be equipped with the Logset TH55, TH65 or TH75 harvester head, all designed for easy and precise operation. The harvester head can be operated fast, yet precise.

### EIGHT WHEELS FOR BETTER PERFORMANCE

The Logset 8H GTE is a steady and strong machine. It brings the operator comfort to a new level. The eight wheels provide the machine an outstanding performance on varying terrain. With the harvester, you have excellent tractive power and stability on steep slopes and flotation in soft ground conditions. In short: when you mount tracks all round you can work where you couldn't go before.

### ECONOMIC

With the fuel-efficient 7,4-liter 6-cylinder diesel engine from AGCO Power, the Logset 8H GTE has enough power and torque to push the single or double hydraulic pump. Thanks to the successful combination of engine size, hydraulics and the new Logset designed TOC-MD 2, the engine is not strained and the operator notices this clearly in the low fuel consumption.



# LOGSET GTE Harvester



# 8H GTE

Harvester range 12/17 - EN  
We reserve the right to make changes without prior notice.  
All technical specifications are for guidance only.  
The pictures and diagrams do not always show standard versions of the machines.  
Copyright Logset Oy.



**LOGSET**

LOGSET Oy  
Hännisentie 2  
FI-66530 Koivulahti  
FINLAND  
Tel. +358 10 286 3200

**LOGSET**  
SIMPLY BETTER  
[www.logset.com](http://www.logset.com)

SIMPLY BETTER

**LOGSET**

# Key features of the Logset harvester

## FUEL AND HYDRAULIC TANKS

The total volume of the fuel tanks is 600 litres. The larger fuel tanks mean less down time for fuel filling and more productive time in the forest. Also, the hydraulic oil tank volume has been increased. The tanks can be tilted to the side when service access to the hydraulic pumps is required.

## CABIN

The cabin has excellent all-round visibility. The upgraded work light guard protects the work lights and cabin roof even better. The new design decreases the transportations height and gives the cabin an eye-pleasing, round profile. The cabin's low noise level is a key factor for operator comfort.

## CONTROL SYSTEM TOC-MD 2

Logset's own control system, the Total Operation and Control Measuring Device 2 (TOC-MD 2) for the harvester head maximizes the production and is easy to navigate and to use. The technology is thoroughly proven through the years. Features like the adaptive feed optimization make the operator's life easier and the machine more productive.

## CRANE

The strong Mesera 240H parallel crane has an optimal geometry. The unique stability of the machine allows you to utilize the crane power up to 11.1 meter reach area. The crane can be operated fast yet precise.



## ENGINE

The powerful 220 kW (300 hp) AGCO Power engine with SCR technology delivers high torque at low engine speed, offering the best fuel economy on the engine market.

## TRANSMISSION

The transmission is controlled and optimized by the TOC 2 control system. The combination of reliable NAF-bogies both in the front and back and a powerful frame lock system which uses large hydraulic cylinders ensure the perfect stability of the harvester. Hydraulically balanced front bogies or mechanically balanced bogies all around are available as optional equipment.

## HYDRAULICS

The Logset 8H GTE can offer up to 495 l/min at 1 500 rpm, which is the correct flow for high productivity and better fuel economy. A right balance for the best output.

## HARVESTER HEAD

The full range of Logset TH harvester heads allows you to select a head that best meets your needs. The most suitable sizes for the Logset 8H GTE are the heads TH55, TH65 and TH75. By choosing a Logset TH harvester head you increase your production, since the head functions seamlessly with the harvester.

# Technical data

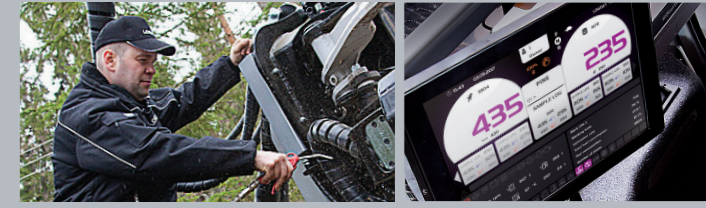

MODEL	8H GTE
<b>DIMENSIONS</b>	
Own weight, kg from	22 000 (48 800 lbs)
<b>ENGINE</b>	
Type	AGCO Power 74 AWF
Stage	EU Stage IV / EPA Tier 4 final
Power at 1 900 rpm, kW	220 (300 hp)
Torque at 1 500 rpm, Nm	1 200 (885 ft lb)
Fuel tank, l	600 (156 US gal)
DEF, l	40 (11 US gal)
<b>TRANSMISSION</b>	
Type	Hydrostatic mechanical
Tractive effort, kN	190 (42 700 lbf)
Gear box	2 gears
<b>HYDRAULIC SYSTEM</b>	
Flow 1 000 rpm, l/min	standard: 210 (55 US gal) option: 140+190 (37+50 US gal)
Hydraulic oil tank, l	400 (106 US gal)
<b>CABIN</b>	
Control system	TOC 2
Measuring device	TOC-MD 2
Battery voltage	24 V
Safety tested and approved cabin • Rotating and levelling cabin (in option)	
<b>TYRES</b>	
Front	600/55-26.5; 710/45-26.5
Rear	600/55-26.5; 710/45-26.5
<b>CRANE OPTIONS</b>	
Crane	Mesera 240H, Mesera 220H
Lifting capacity, kNm	240 (177 020 ft lb)
Reach options, m	10.3/11.1 (34/36 ft)
<b>HARVESTER HEADS</b>	
Model options	TH55, TH65, TH75
<b>OPTIONAL EQUIPMENTS</b>	
Contact your local dealer for more information about options	

## LOGSET 8H GTE

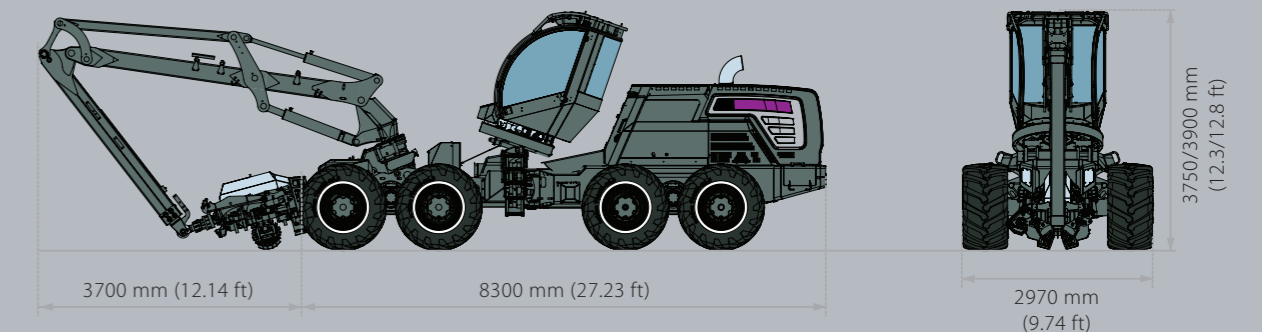

SIMPLY BETTER

LOGSET