

LOGSET Harvester Head



TH85

Optimized for large scale clearfell harvesting

Logset TH85 is the second largest head in Logset's TH range. Together with the Logset 12H GTE Hybrid harvester, it takes productivity to unseen levels.

Logset TH85 is designed for felling, feeding and cross-cutting trees between 80 cm and 4 cm in diameter. Its three feeding wheels and four hydraulic motors provide an impressive feeding force with even the most difficult trees. Its total weight of 2 100 kg makes for a reliable structure in terms of chassis, knives and pivots. The saw unit can be equipped with either 0,404" or $\frac{3}{4}$ " pitch saw chains and up to a 1-meter saw bar.

Logset TH85 has all the elements needed for a great cutting experience: performance and efficiency.

As a standard, all the heads in the TH range come with the TOC-MD 2 measuring device. The user interface allows you to easily use and adjust features such as proportional knife control, automatic cross cutting, and feeding speed. The seamless integration of TOC-MD 2 with the head guarantees high productivity.

SIMPLY BETTER

LOGSET

LOGSET Harvester Head TH85

All knife blades are made from hardened wear resistant material

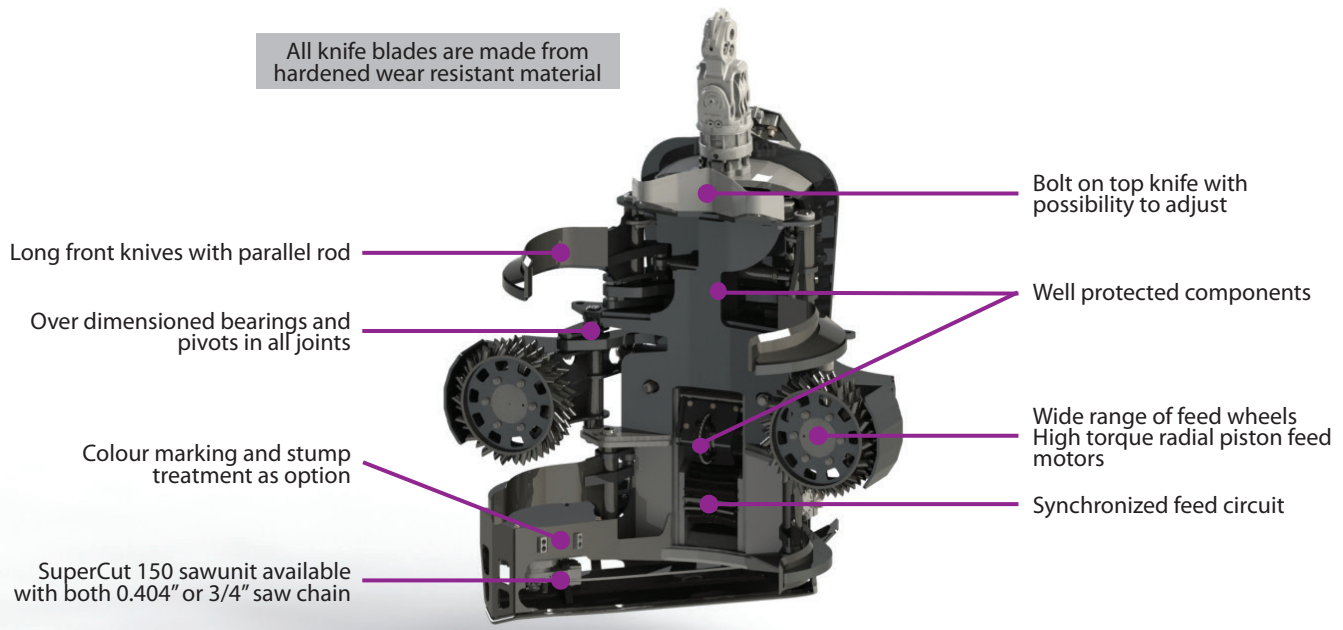

Technical data

DIMENSIONS		
Width, head open	mm	1900 (75 in)
Width, head closed	mm	1580 (62 in)
Height to top knife	mm	1850 (73 in)
Height with rotator and link	mm	2400 (94 in)
Weight with rotator and link	kg	2100 (4 629 lbs)
FELLING/CUTTING		
Max. felling/cutting diameter	mm	900 (35 in)
Saw bar	mm	1000 (39 in)
Saw unit	SuperCut 150	
Saw motor	Bucher 32	
Saw chain tensioning	Hydraulic	
Chain oil tank volume	liter	8 (2 gal)
HYDRAULIC SYSTEM		
Max. pressure	bar	280 (4 061 psi)
Flow required for optimal prod.	l/min	300 (79 gal/min)
Valve block: purpose built hydraulic manifold		
FEEDING		
Hydraulic motors, feeding arms	cm ³	940
Hydraulic motors, chassis	cm ³	470
Number of hydraulic motors	pcs	4
Feeding speed (300 l/min, 79 gal/min)	m/s	4,2 (14 ft/s)
Max. opening, feed wheels	mm	840 (33 in)

DELIMBING		
Max. opening, upper knives	mm	1000 (39 in)
Delimiting diameter tip to tip	mm	580 (23 in)
Number of static knives	pcs	2
Number of movable knives	pcs	4
ROTATOR		
Indexator AV 17/H182, Black Bruin BBR 16		
MEASURING SYSTEM		
Logset TOC-MD 2		
RECOMMENDED BASE MACHINE SIZE		
Wheeled base, from	23-28 t. (51 000-62 000 lbs)	
Tracked base, from	26-32 t. (57 000-71 000 lbs)	
OPTIONAL EQUIPMENT		
Contact your local dealer for more information about options.		

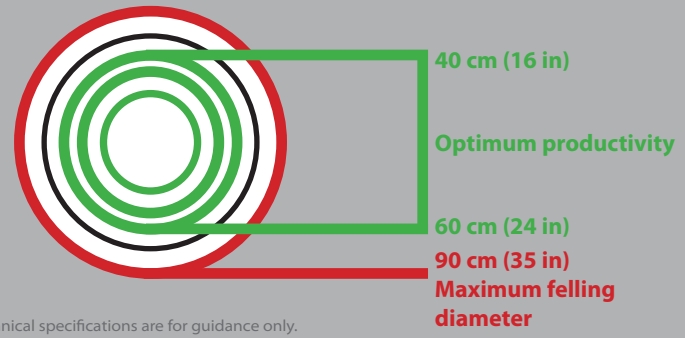

Harvester heads range 12/17 - EN. We reserve the right to make changes without prior notice. All technical specifications are for guidance only. The pictures and diagrams do not always show standard versions of the heads. Copyright Logset Oy.

Logset Oy
 Hännisentie 2
 FI-66530 Koivulahti
 FINLAND
 Tel. +358 10 286 3200

LOGSET
 SIMPLY BETTER
www.logset.com