

LOGSET **GT** Forwarder



10F GT

SIMPLY BETTER

LOGSET

LOGSET 10F GT



POWERFUL 18-TON FORWARDER FOR LONG HAULS

The Logset 10F GT is one of the two big brothers in the Logset forwarder range. This impressive 18-ton forwarder has an exceptionally robust and reliable structure. It has been designed for the toughest climates and terrains, such as those of Russia, North America and Latin America.

RELIABILITY

Logset 10F GT is, like the other Logset products, designed for hard work. The main mechanical parts have been reinforced to achieve long lifespan and to endure challenging conditions. The frames, center joint, bogie attachments, load bay and a solid hood have all been designed for rough forest conditions. The main components have been selected to ensure the best reliability: Less downtime, more money!

ECONOMY

The successful combination of the Logset TOC 2 control system and the AGCO Power diesel engine makes Logset probably the most fuel-efficient forwarder manufacturer. High-resistance parts, exceptional reliability and minimized downtime contribute to low running costs.

PRODUCTIVITY

The Logset 10F GT forwarder has a Mesera 111 crane as standard equipment. The crane has an impressive 151 kNm lifting force, which makes it suitable for lifting heavy logs and even full-length trees. The diesel engine with 220 kW (300 hp), in combination with the hydrostatic transmission, provides sufficient power in all situations. You can work with high productivity even in difficult conditions.

COMFORT

The operator's comfort is crucial for maximizing productivity. The spacious cabin offers excellent visibility and a low noise level. The main components of the forwarder are easily accessible, making service easy.

LOGSET

Eight advantages with the Logset forwarder

ENGINE

The diesel engine in the Logset forwarder range has the best combination of excellent fuel economy and outstanding power. The latest SCR technology is used in the engines to make them environmentally friendly.

CABIN

The cabin offers first-class comfort and an unobstructed view both when driving and loading. It is spacious and has large storage compartments. The forwarder is easy to maneuver because the wheels are in sight.



FUEL AND HYDRAULIC TANKS

Thanks to the 240 liters fuel tank capacity, the operator can extend the work shift without refueling. The correct dimensioning of the oil tank in each machine model ensures a longer lifespan of the hydraulic components.

TRANSMISSION

The machine is available with or without balancing on the NAF bogies, according to the needs.

CRANE

A great advantage of the Mesera crane is its boom geometry. The crane is especially designed for forwarders, and loading and unloading is comfortable and easy. You can choose from two crane models: either the Mesera 111 crane with a reach from 7.2 meters to 8.5 meters (151 kNm) or the Mesera 122 crane with a reach from 8.1 meters to 10 meters (155 kNm). Both models are available with integrated hoses.



TOTAL OPERATION AND CONTROL SYSTEM 2 (TOC 2)

The forwarder is equipped with the user-friendly Logset TOC 2 control system. Thanks to the control system, the operator saves fuel while the driving experience is soft and smooth. The crane control is also fast and accurate. If the machine has several operators, they can save their personalized settings for the crane.

TRACTIVE EFFORT

The hydrostatic transmission gives the best performance even in the most difficult terrains. It is powerful, accurate and reliable. The Logset 10F GT forwarder is especially designed for long hauls.

LOAD BAY

The strong, adjustable and durable load bay carries more wood than ever before. The Logset 10F GT can easily be loaded with two stacks of 3-meter logs. The machine can carry up to 18 tons of timber.



Technical data



MODEL

10F GT

DIMENSIONS

Own weight from, kg	22 000 (48 500 lbs)
Load capacity, kg	18 000 (39 700 lbs)
Load area length, m	5.4/6.1 (213/240 in)

ENGINE

Type	AGCO Power 74 AWF
Stage	EU Stage IV / EPA Tier 4 final
Power at 1900 rpm, kW	220 (300 hp)
Torque at 1500 rpm, Nm	1 200 (885 ft lb)
Fuel tank, l	240 (63 US gal)
DEF tank, l	30 (7.9 US gal)

TRANSMISSION

Type	Hydrostatic mechanical
Tractive effort, kN	220 (49 450 lbf)
Gear box	2 gears

HYDRAULIC SYSTEM

Pump size, cm ³	180
Pressure, MPa	21.5 (3 118 psi)
Oil tank, l	175 (46 US gal)

CABIN

Control system: TOC 2 • Battery Voltage: 24V • Safety tested and approved cabin

WHEELS

Tyres	750/55-26.5
-------	-------------

CRANE OPTIONS

Crane	Mesera 111, Mesera 122
Lifting capacity, kNm	151/155 (111 370/114 320 ft lb)
Reach options, m	7.2/7.8/8.5/9.1/10 (283/307/335/358/394 in)
Rotator, °	360

OPTIONAL EQUIPMENT

Bulldozer blade • Diesel heater • Crane tilt • Contact your local dealer for more information about other options

LOGSET 10F GT

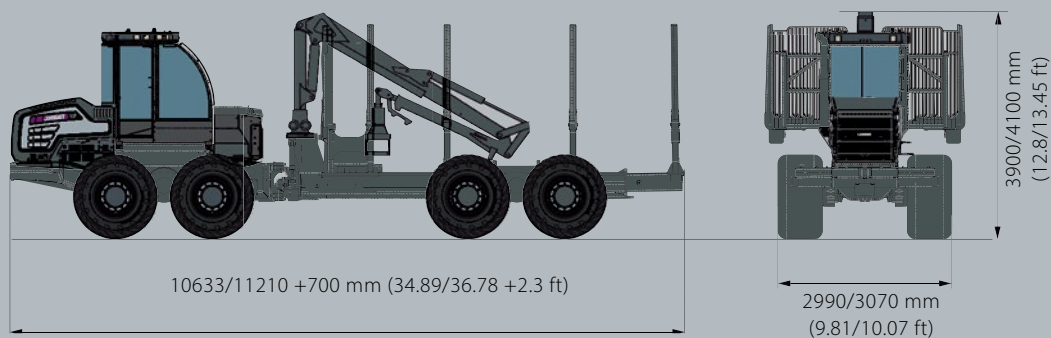

SIMPLY BETTER

LOGSET



Forwarder range 01/22 - EN

We reserve the right to make changes without prior notice.

All technical specifications are for guidance only.

The pictures and diagrams do not always show standard versions of the machines.

Copyright Logset Oy.



LOGSET Oy
Hännisentie 2
FI-66530 Koivulahti
FINLAND
Tel. +358 10 286 3200

LOGSET
SIMPLY BETTER

www.logset.com