

TH60 FOR THINNING OPERATIONS AND SMALL-SIZED CLEARFELLS

Logset TH60 is compact head with four movable knives. Highly productive head is designed for thinning and clearfelling of mid-sized timber. It is excellent choice for mid-sized harvesters with long reach cranes. The three-roller synchronized feed system ensures powerful and precise feeding in all conditions.

The TH60 is part of the latest 4.0 series, which includes improved hydraulic valve block, smooth oil flow, outstanding saw control, improved serviceability and house routing.

TH60 PERFORMS PERFECTLY on bent timber because of long front knives equipped with the parallel rod, large tilt angle and short frame. The diameter of the timber is measured from the front knives with two sensors, which guarantees reliable diameter measurement. Hydraulic length measuring wheel with adjustable pressure, and wide range of measuring wheel options ensures a precise length measurement in all conditions. The head can be equipped with custom knives, feeding wheels, and software for efficient bunch processing.

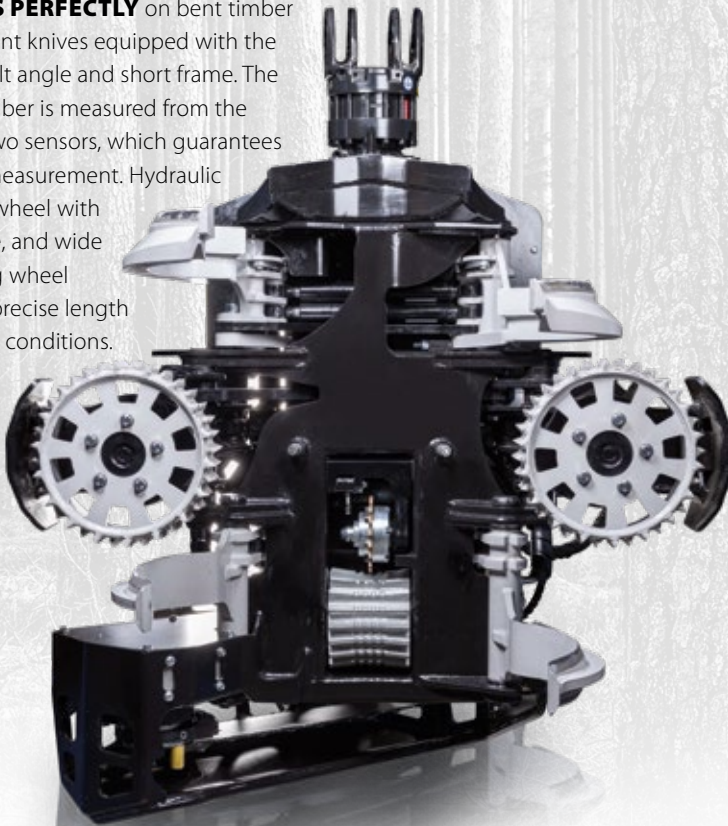

OWN WEIGHT **1,2^T**

BASE MACHINE **14-18^T** FEED SPEED **6/4,7^{M/S}**

LOGSET TH60 4.0

DIMENSIONS

Width, head open	1420 mm (55.9")
Width, head closed	1200 mm (47.2")
Height to top knife	1300 mm (51.2")
Height with rotator and link	1820 mm (71.7")
Weight with rotator and link	1200 kg (2 645 lbs)

FELLING / CUTTING

Max felling/cutting diameter	650 mm (25.6")
Saw bar	750 mm (29.5")
Saw unit	SuperCut 100S
Saw motor	Parker/Bucher
Saw chain tensioning	Automatic
Chain oil tank volume	8 l (2.1 US gal)

HYDRAULIC SYSTEM

Max pressure	280 bar (4061 PSI)
Flow for optimal production	160 l/min (42.3US gal/min)
Valve block	Purpose built hydraulic

FEEDING

Hydraulic motors, feed arms	500/630 cm ³
Hydraulic motors, chassis	315/400 cm ³
Number of hydraulic motors	4 pcs
Feeding force	27/31 kN (6070/6969 lbf)
Feeding speed, 300 l/min	6.0/4.7 m/s (19.7/15.4 ft/s)
Max open, feeding wheels	630 mm (24.8")

DELIMBING

Max opening, upper knives	680 mm (26.8")
Max opening, rear knives	-
Optimal productivity	10-40 cm (3.9-15.7")
Delimiting diameter tip to tip	450 mm (17.7")
Number of static knives	1 pc
Number of movables knives	4 pcs
Max tilt angle	140°

ROTATOR OPTIONS

Indexator AV12S, H122	
BBR 15H	

MEASURING DEVICE

Logset TOC-MD 2	
-----------------	--

RECOMMENDED BASE MACHINE

Wheeled base	14-18 t (30 860-39 680 lbs)
Tracked base	16-20 t (35 270-44 090 lbs)

OPTIONAL ACCESSORIES

Contact your local dealer for more information.